

Name	Signatur	Datum	Artikelnummer	Oberfläche: Roh
Ch. Höfig	CH	27.10.2020	60191-ZN0	
Werkstoff:				Blattformat
Zink AG40A (Zn-4Al-0,4Mg)				A4
Gewicht 0,079 kg		Maßstab: 1:1	Version: 1	Blatt 1 von 5

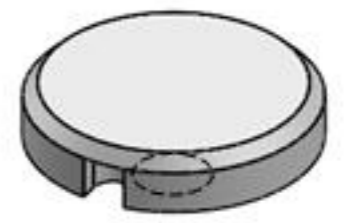

Name	Signatur	Datum	Artikelnummer	Oberfläche: Roh
Ch. Höfig	CH	27.10.2020	6019X-ZN0 Teil1	
Werkstoff:				Blattformat
Zink AG40A (Zn-4Al-0.4Mg)				A4
Gewicht 0.028 kg		Maßstab: 1:1	Version: 1	Blatt 2 von 5

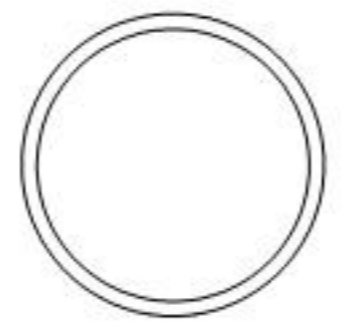
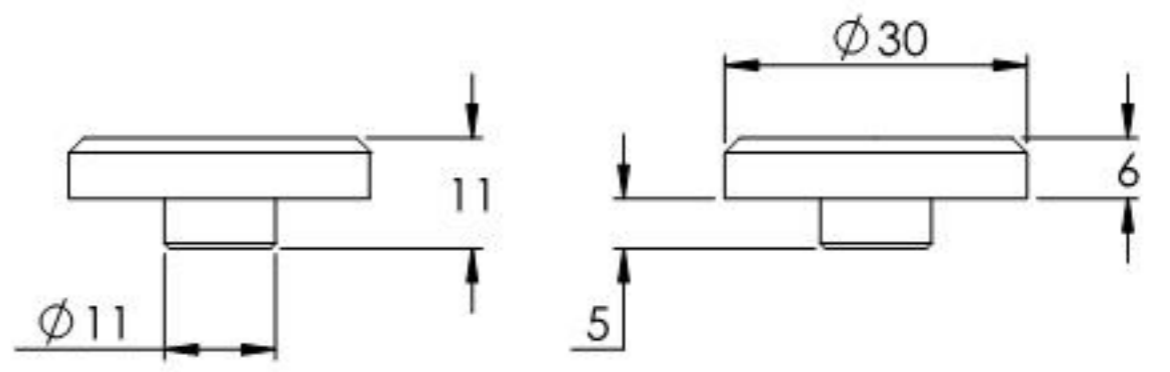
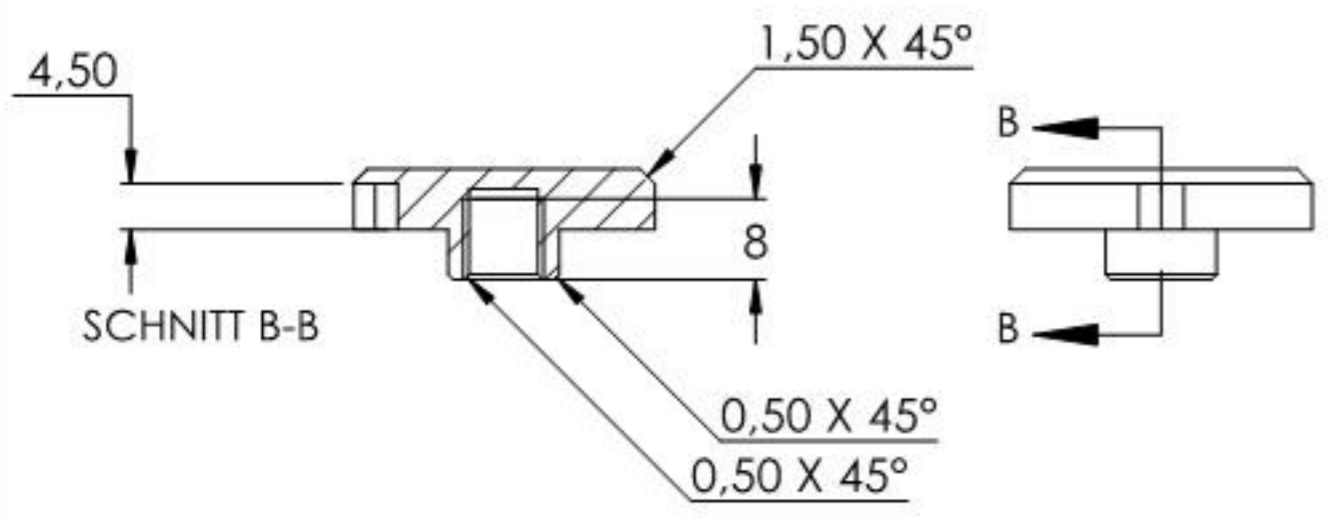
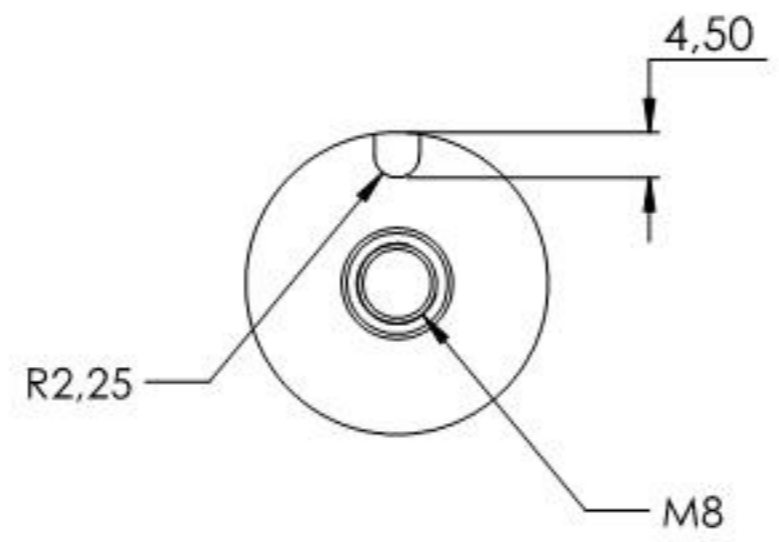
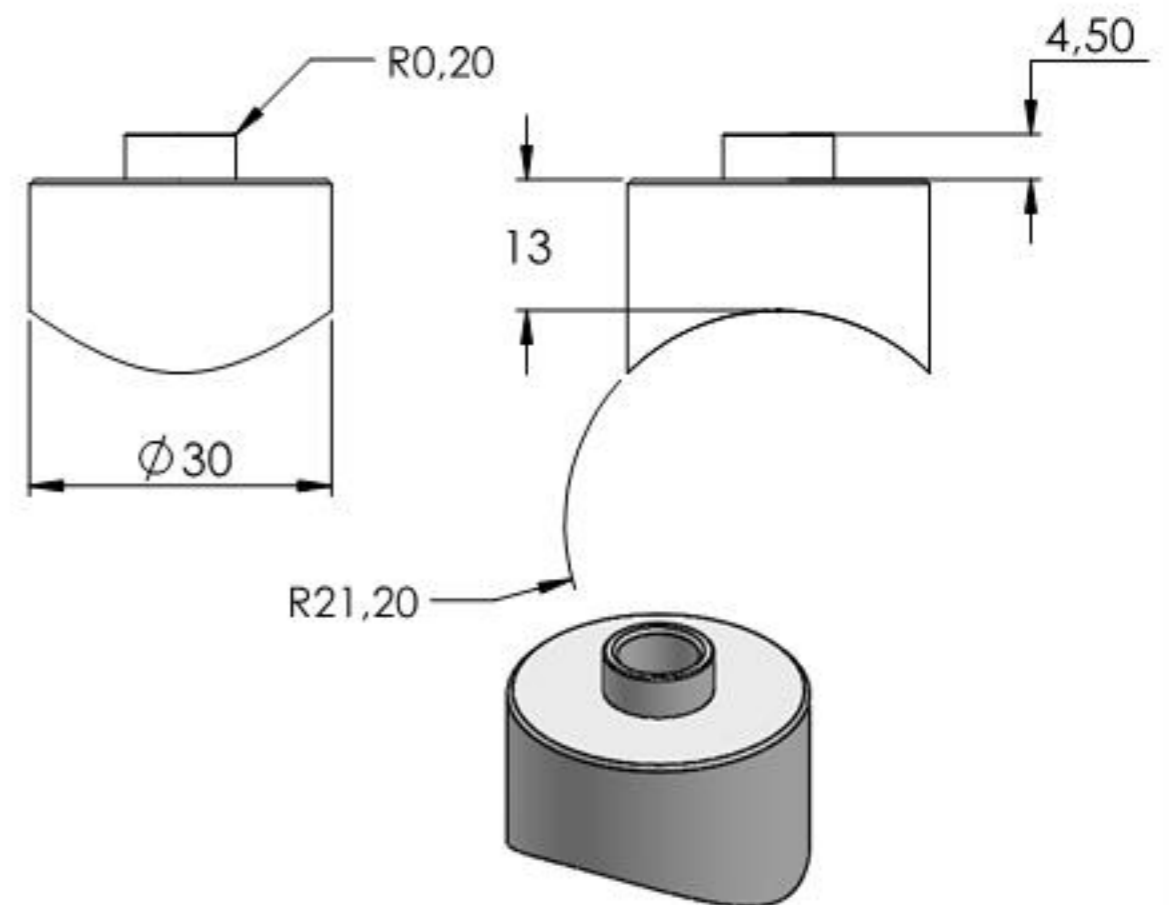
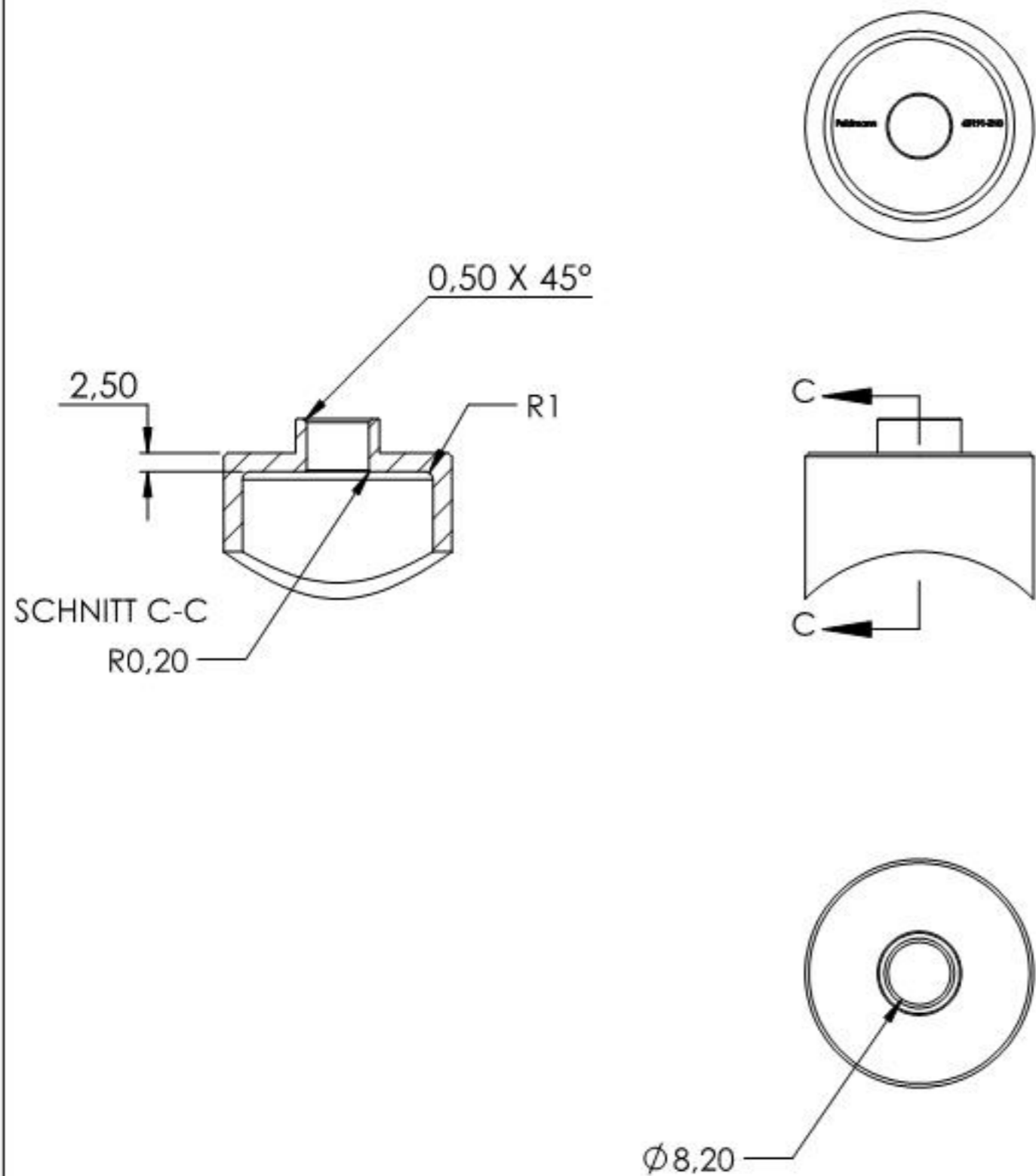

Name	Signatur	Datum	Artikelnummer	Oberfläche: Roh
Ch. Höfig	CH	27.10.2020	60191-ZN0 Teil2	
Werkstoff:				Blattformat
Zink AG40A (Zn-4Al-0,4Mg)				A4
Gewicht 0,031 kg		Massstab: 1:1	Version: 1	Blatt 3 von 5