

Name	Signatur	Datum	Artikelnummer	Oberfläche: Geschliffen Korn 240
Ch. Höfig	CH	30.09.2020	50429-240	
Werkstoff:		Hersteller		Blattformat
1.4301 (X5CrNi18-10)		 <b>Feldmann</b> <small>EDLSTAHL · ALUMINIUM · SCHWEIßEISEN</small>		A4
Gewicht 0.028 kg		Maßstab: 1:1	Version: 1	Blatt 1 von 4

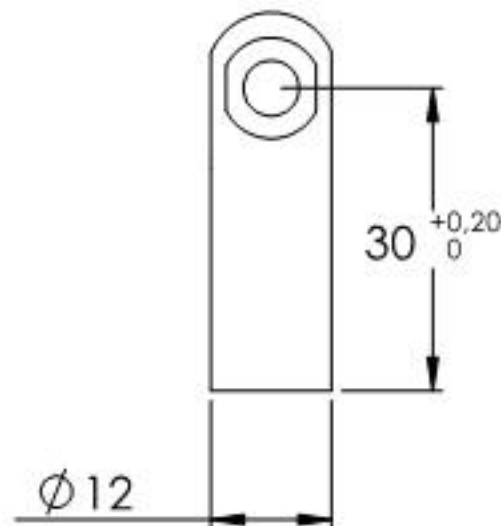

Name	Signatur	Datum	Artikelnummer	Oberfläche: Geschliffen Korn 240
Ch. Höfig	CH	30.09.2020	50429-240 Teil1	
Werkstoff:		Hersteller		Blattformat
1.4301 (X5CrNi18-10)		 <small>EDLSTAHLE · ALUMINIUM · SCHWEIßEISEN</small>		A4
Gewicht 0,012 kg		Maßstab: 1:1	Version: 1	Blatt 2 von 4

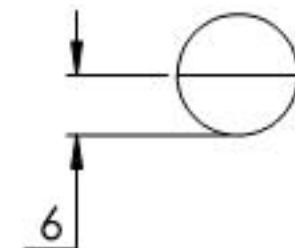
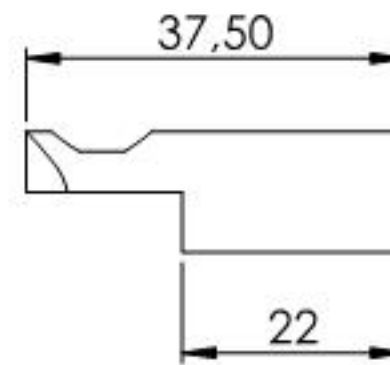
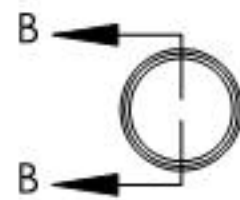
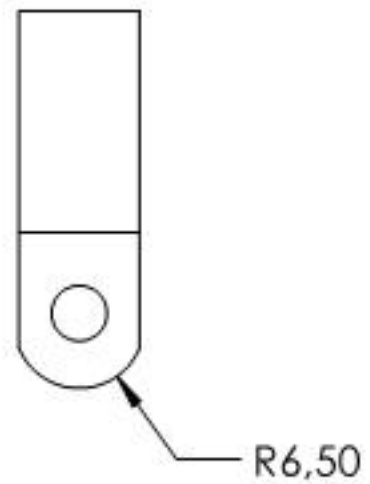
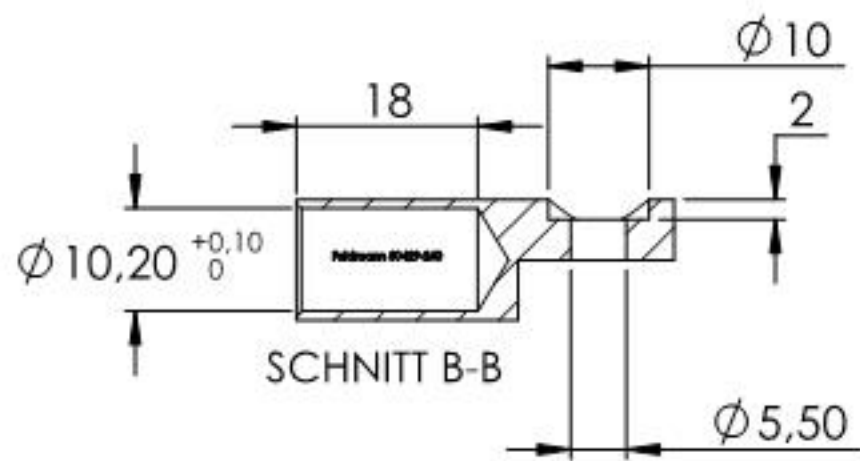
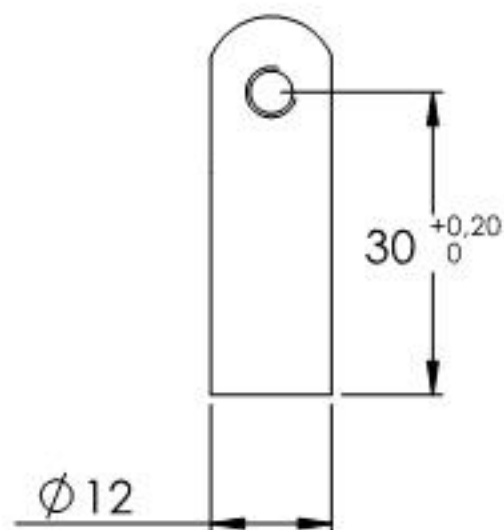
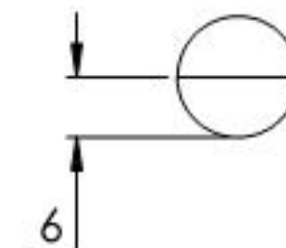
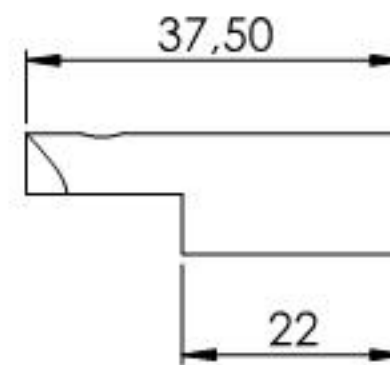
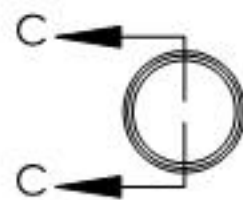
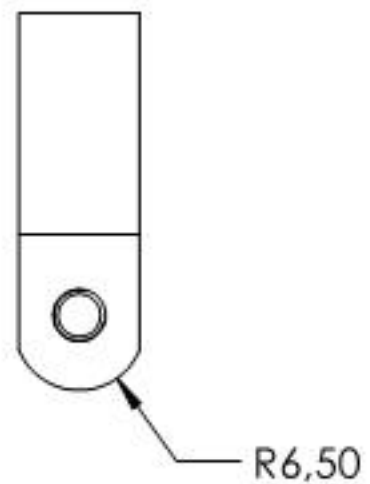
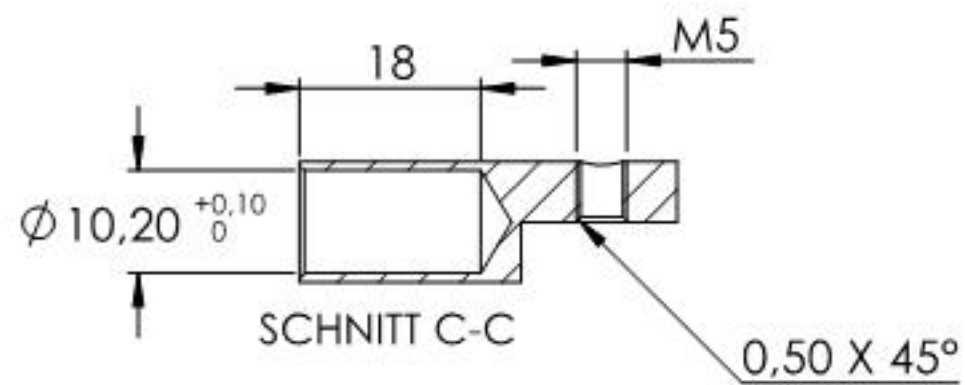

Name	Signatur	Datum	Artikelnummer	Oberfläche: Geschliffen Korn 240
Ch. Höfig	CH	30.09.2020	50429-240 Teil2	
Werkstoff:		Hersteller		Blattformat
1.4301 (X5CrNi18-10)		 <small>EDLSTAHLE · ALUMINIUM · SCHWEIßEISEN</small>		A4
Gewicht 0.013 kg		Maßstab: 1:1	Version: 1	Blatt 3 von 4