

Name	Signatur	Datum	Artikelnummer	Oberfläche: Geschliffen Korn 240
Ch. Höfig	CH	12.10.2020	50419-240	
Werkstoff:				Blattformat
1.4301 (X5CrNi18-10)				A4
Gewicht 0.107 kg		Maßstab: 1:1	Version: 1	Blatt 1 von 4

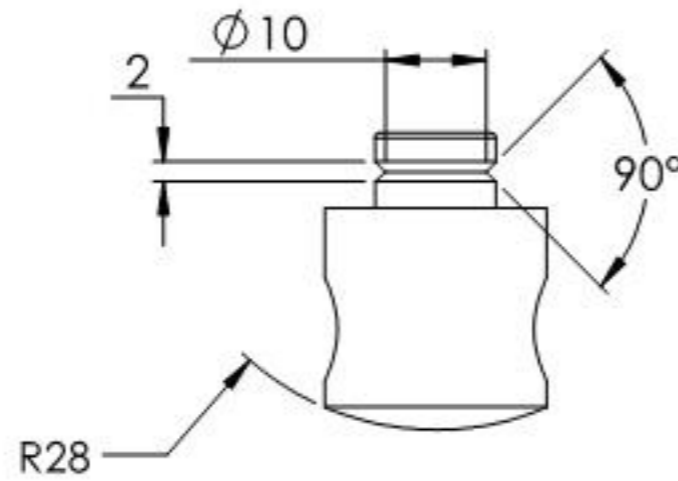

Name	Signatur	Datum	Artikelnummer	Oberfläche: Geschliffen Korn 240
Ch. Höfig	CH	12.10.2020	50419-240 Teil1	
Werkstoff:				Blattformat
1.4301 (X5CrNi18-10)				A4
Gewicht 0.055 kg		Massstab: 1:1	Version: 1	Blatt 2 von 4

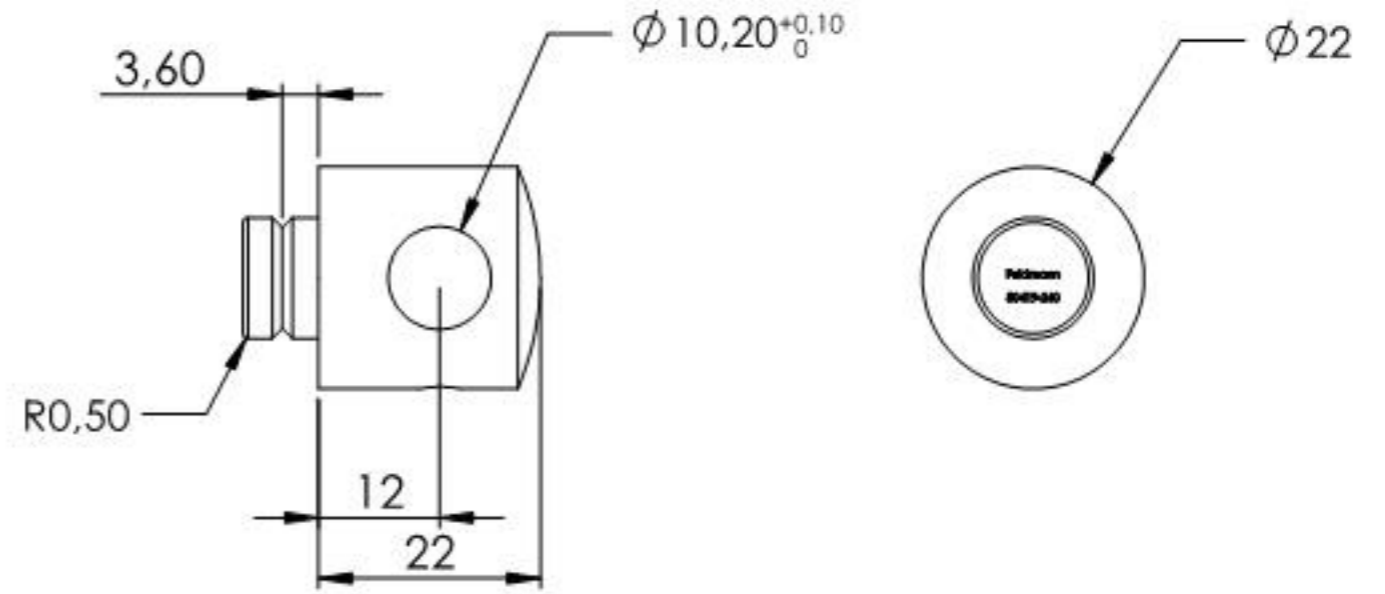
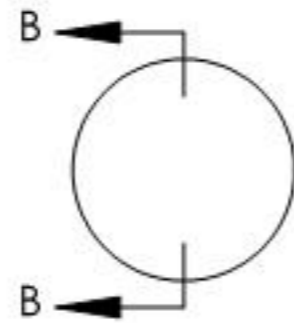
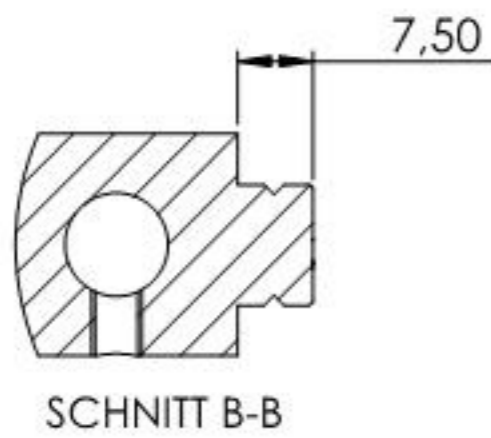
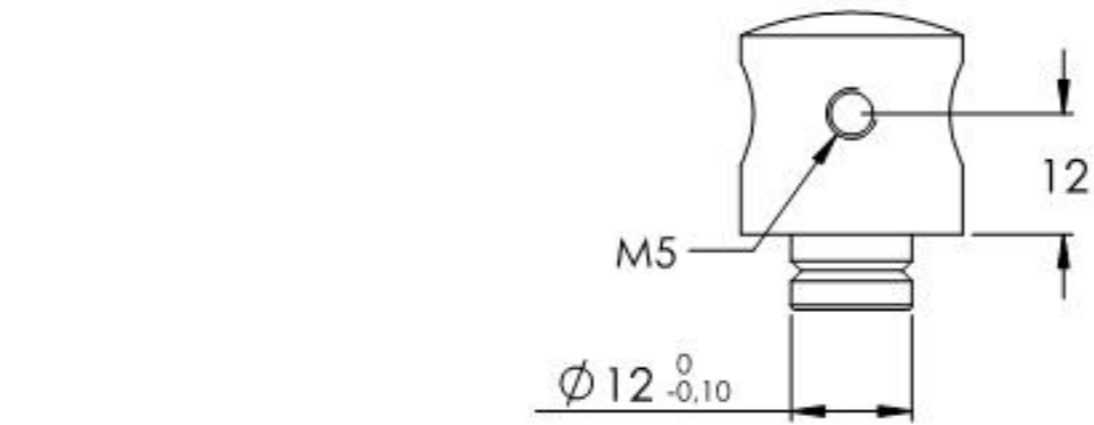
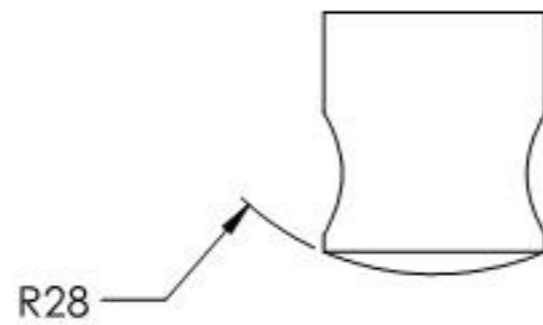
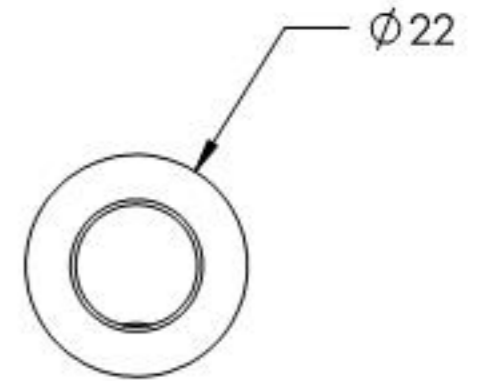
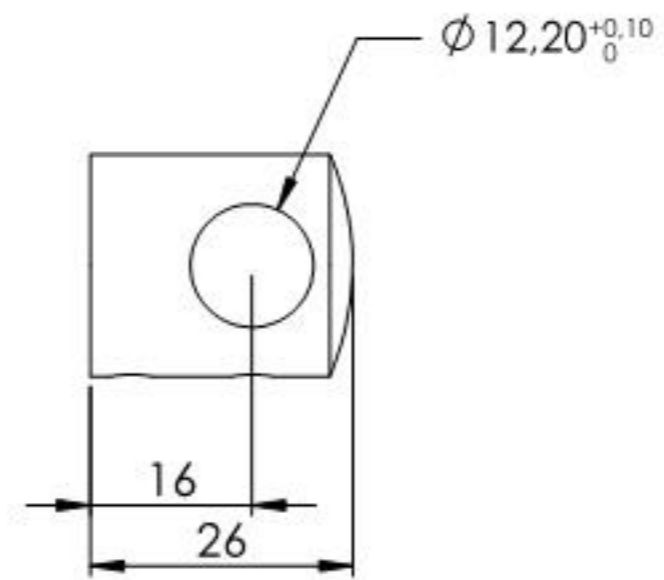
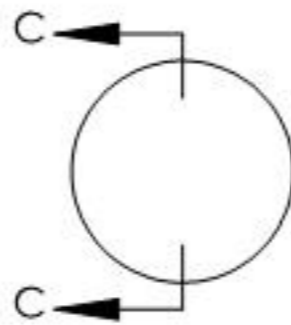
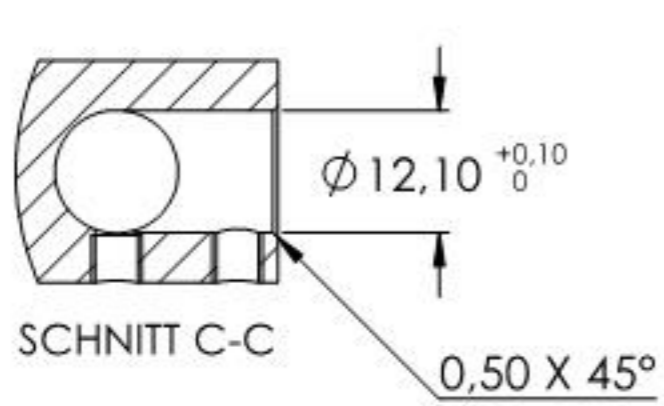
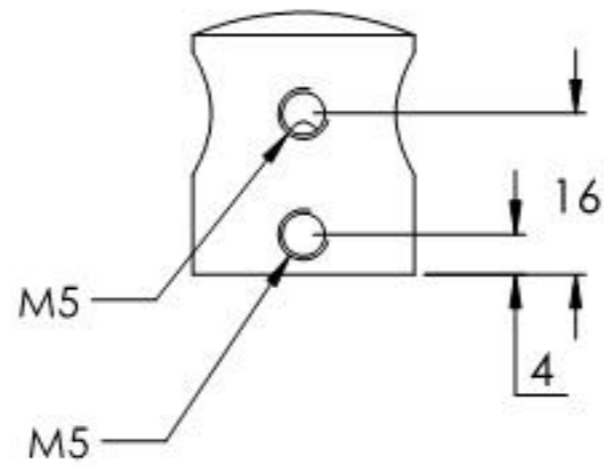

Name	Signatur	Datum	Artikelnummer	Oberfläche: Geschliffen Korn 240
Ch. Höfig	CH	12.10.2020	50419-240 Teil2	
Werkstoff:				Blattformat
1.4301 (X5CrNi18-10)				A4
Gewicht 0,044 kg		Maßstab: 1:1	Version: 1	Blatt 3 von 4