

Name	Signatur	Datum	Artikelnummer	Oberfläche: Elektropoliert
Ch. Höfig	CH	22.09.2023	101200303	
Werkstoff: 1.4401/04 (X5CrNiMo17-12-2)			Hersteller	Blattformat
				A4
Gewicht: 0.023 kg			Maßstab: 1:1.5	Version: 1 Deutsch Blatt 1 von 5

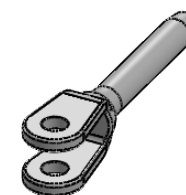

Name	Signatur	Datum	Artikelnummer	Oberfläche: Elektropoliert
Ch. Höfig	CH	22.09.2023	101200303 Teil 1	
Werkstoff: 1.4401/04 (X5CrNiMo17-12-2)			Hersteller	
Gewicht: 0.019 kg			Maßstab: 1:1.5	Version: 1 Deutsch Blatt 2 von 5
				Blattformat A4

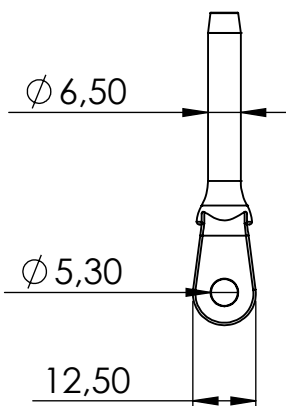
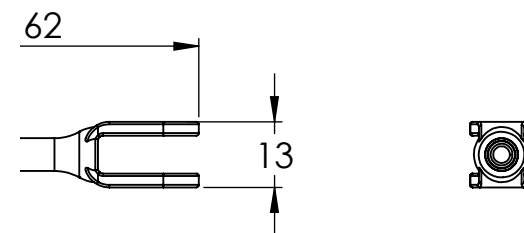
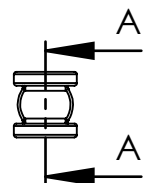
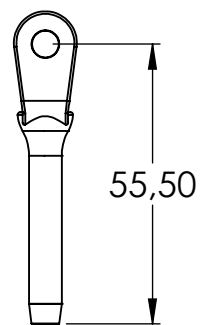
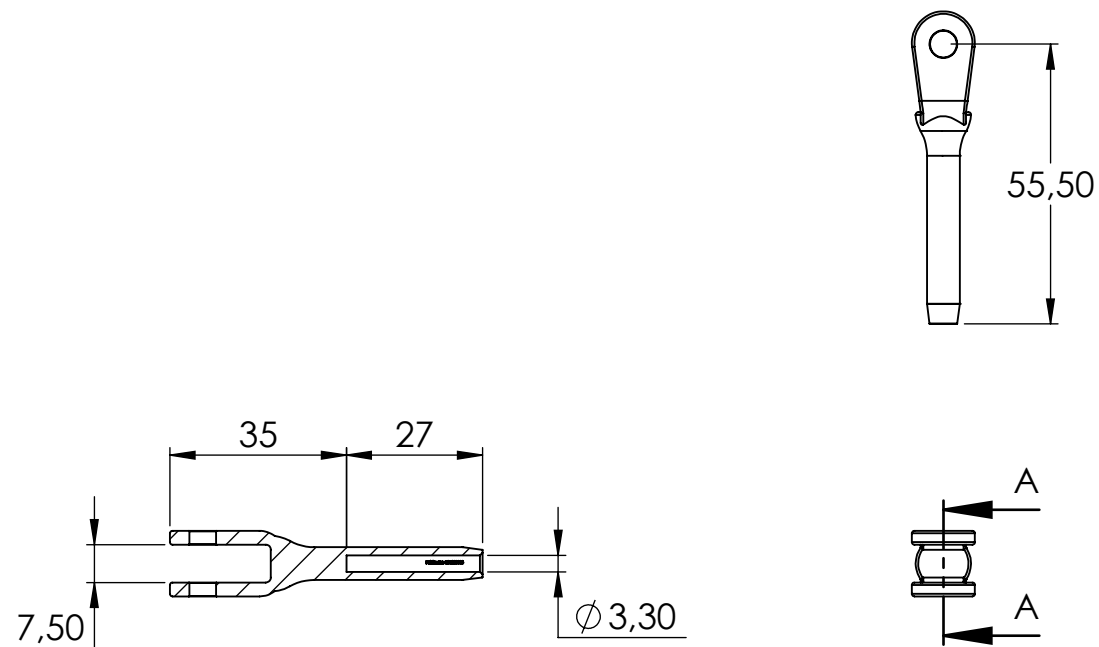
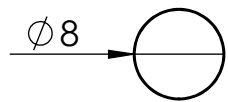
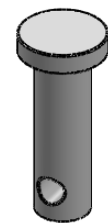
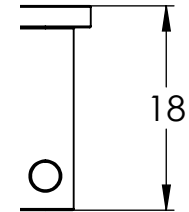
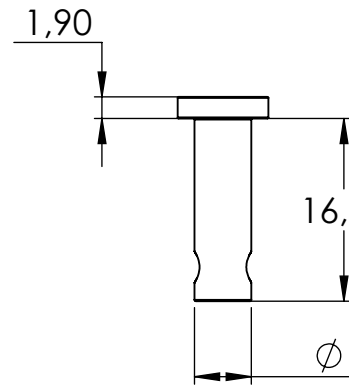
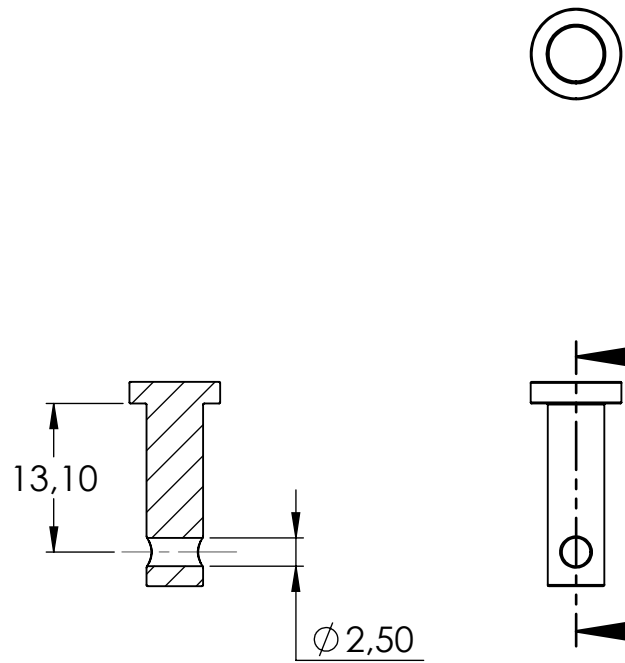

Name	Signatur	Datum	Artikelnummer	Oberfläche: Elektropoliert
Ch. Höfig	CH	22.09.2023	101200303 Teil2	
Werkstoff: 1.4401/04 (X5CrNiMo17-12-2)			Hersteller	Blattformat
				A4
Gewicht: 0.003 kg			Maßstab: 1.5:1	Version: 1 Deutsch Blatt 3 von 5

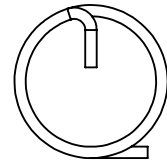
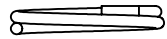
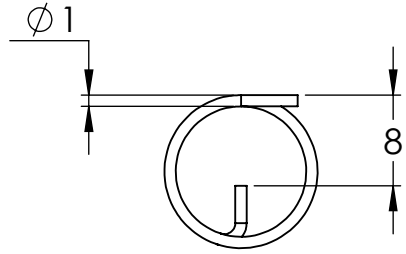

Name	Signatur	Datum	Artikelnummer	Oberfläche: Elektropoliert
Ch. Höfig	CH	22.09.2023	101200303 Teil3	
Werkstoff: 1.4401/04 (X5CrNiMo17-12-2)			Hersteller	Blattformat
				A4
Gewicht: 0.000 kg			Maßstab: 1.5:1	Version: 1 Deutsch Blatt 4 von 5

POS-NR.	BENENNUNG	MENGE
1	101200303 Teil1	1
2	101200303 Teil2	1
3	101200303 Teil3	1

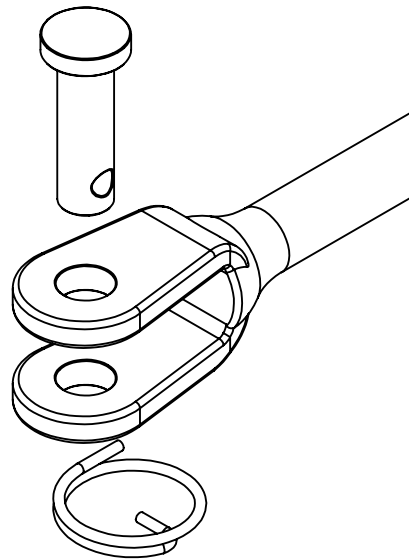

Name	Signatur	Datum	Artikelnummer	Oberfläche: Elektropoliert
Ch. Höfig	CH	22.09.2023	101200303	
Werkstoff: 1.4401/04 (X5CrNiMo17-12-2)			Hersteller	Blattformat
				A4
Gewicht: 0.023 kg			Maßstab: 1.5:1	Version: 1 Deutsch Blatt 5 von 5