

Name	Signatur	Datum	Artikelnummer	Oberfläche: Elektropoliert
Ch. Höfig	CH	22.09.2023	101200808	
Werkstoff: 1.4401/04 (X5CrNiMo17-12-2)				Blattformat A4
Gewicht: 0.121 kg		Maßstab: 1:1.5	Version: 1	Deutsch
Blatt 1 von 5				

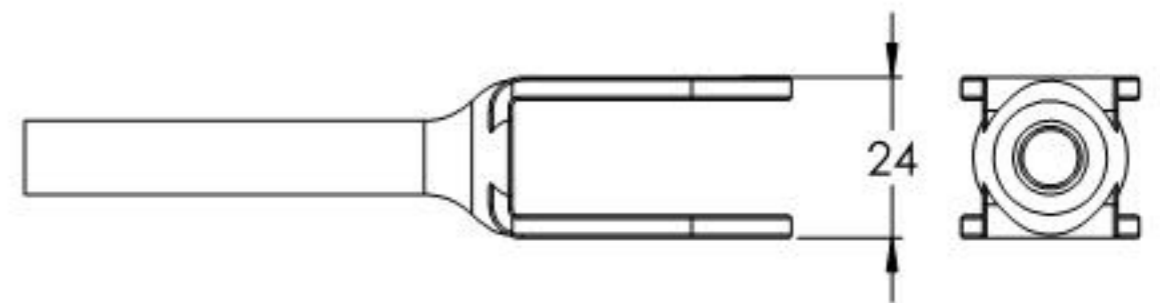

Name	Signatur	Datum	Artikelnummer	Oberfläche: Elektropoliert
Ch. Höfig	CH	22.09.2023	101200808 Teil1	
Werkstoff:				Blattformat
1.4401/04 (X5CrNiMo17-12-2)				A4
Gewicht: 0.089 kg		Maßstab: 1:1.5	Version: 1	Deutsch
			Blatt 2 von 5	

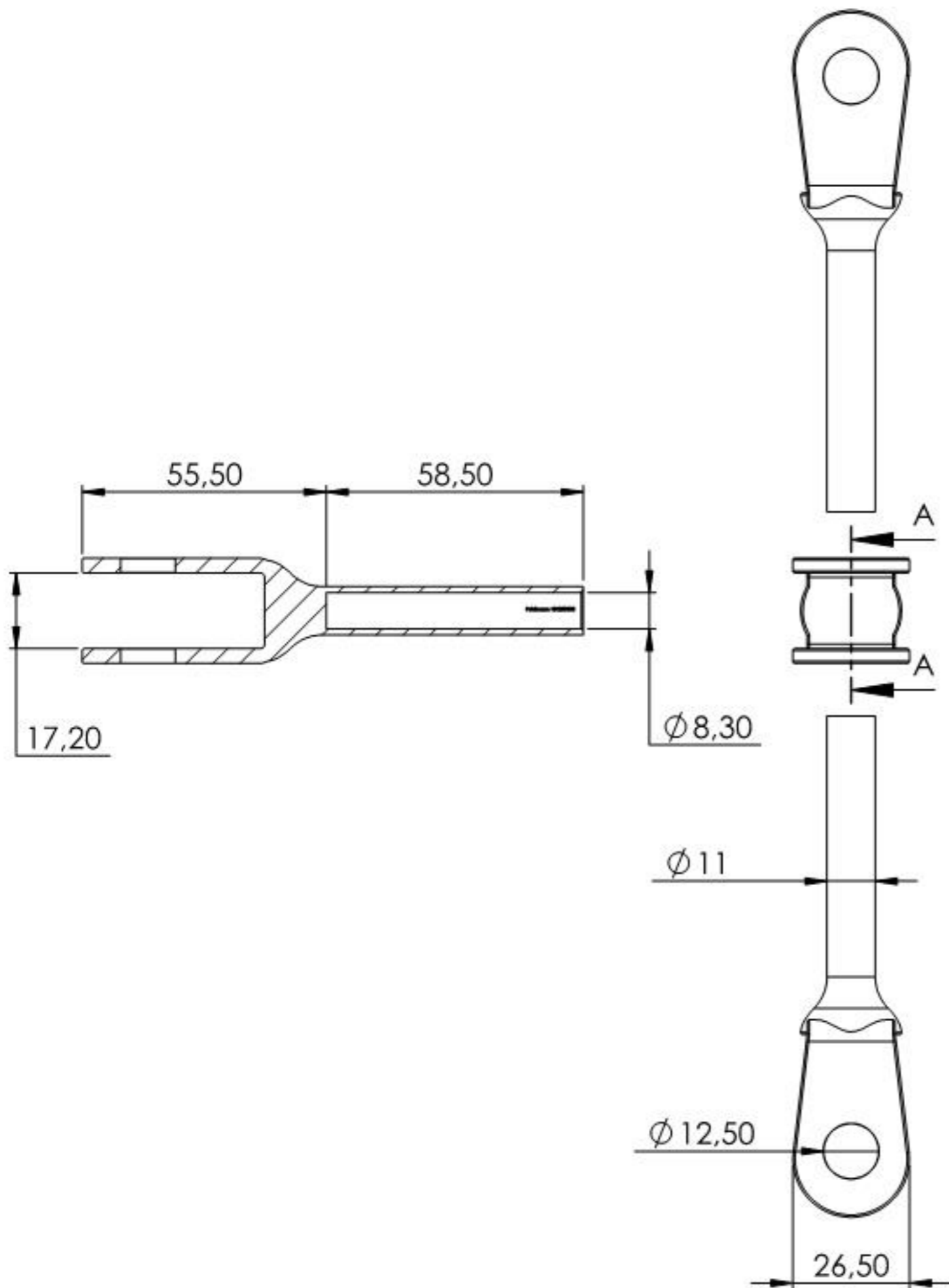
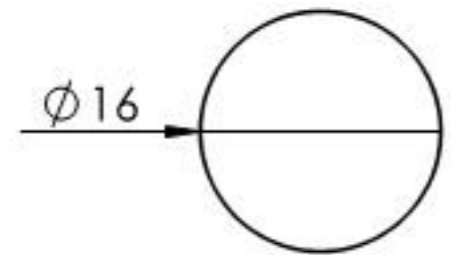
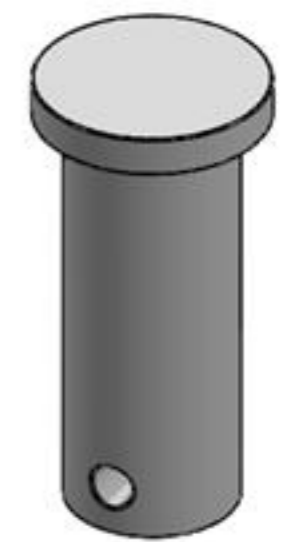
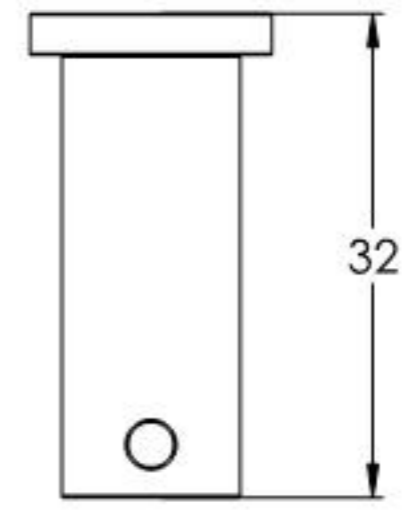
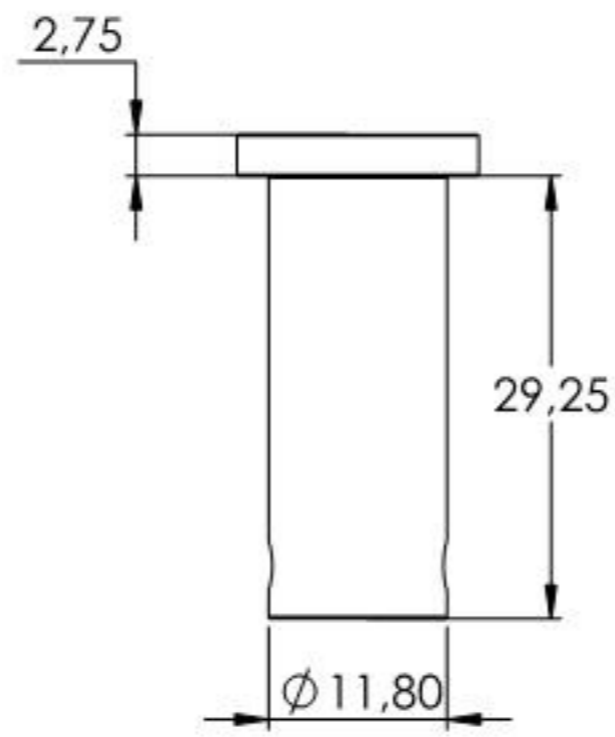
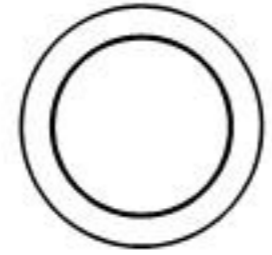
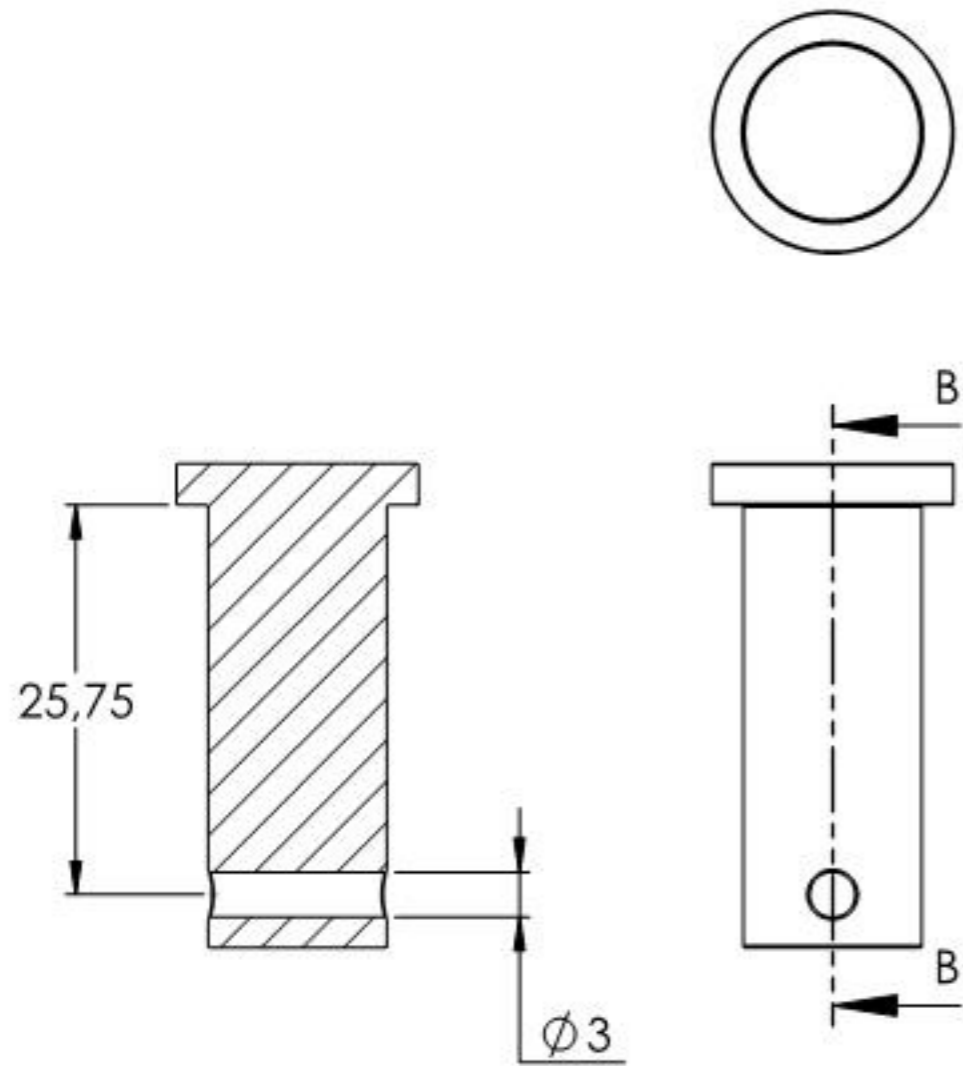

Name	Signatur	Datum	Artikelnummer:	Oberfläche: Elektropoliert
Ch. Höfig	CH	22.09.2023	101200808 Teil2	
Werkstoff:				Blattformat
1.4401/04 (X5CrNiMo17-12-2)				A4
Gewicht: 0.029 kg		Maßstab: 1.5:1	Version: 1	Deutsch
				Blatt 3 von 5