

SCHNITT A-A

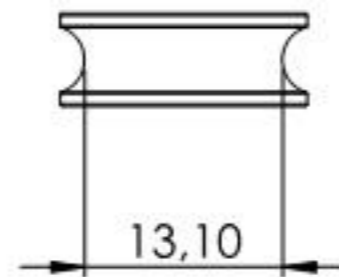
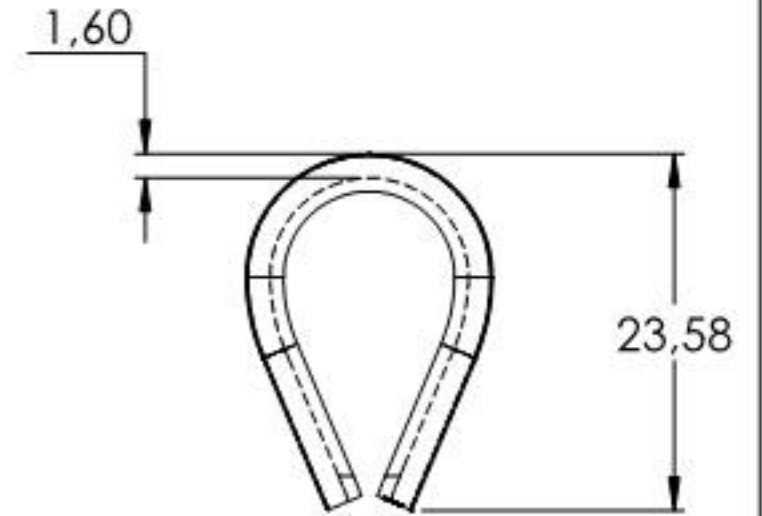
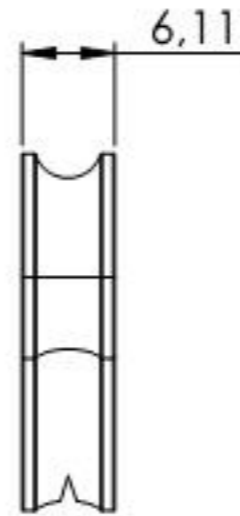

Name	Signatur	Datum	Artikelnummer	Oberfläche: Elektropoliert
Ch. Höfig	CH	19.09.2019	100052004	
Werkstoff:				Blattformat
1.4401/04 (X5CrNiMo17-12-2)				A4
Gewicht 0,003 kg		Massstab: 1,5:1	Version: 1	Blatt 1 von 1