

SCHNITT B-B

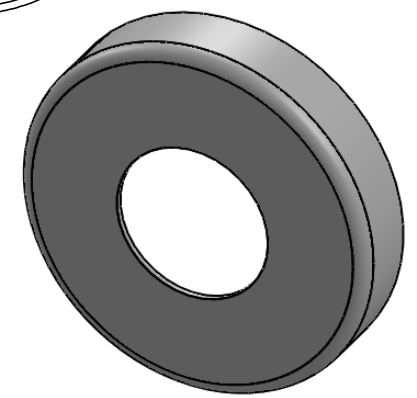

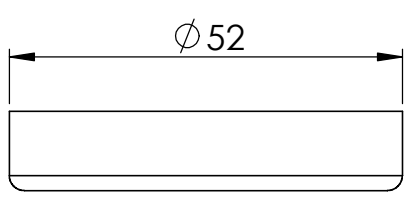

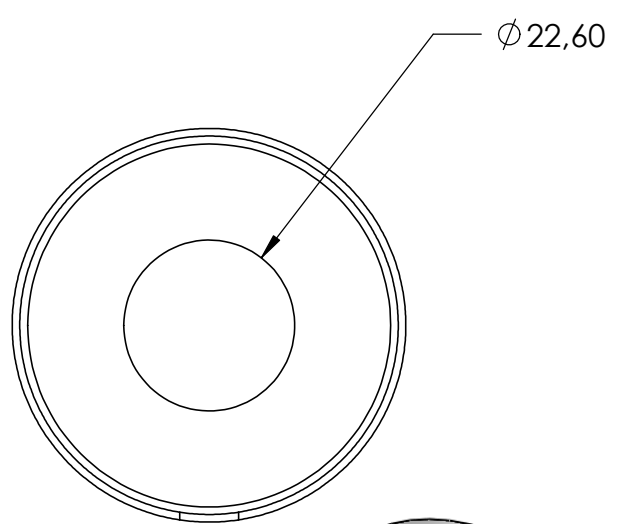
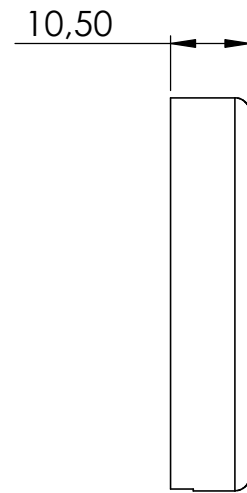
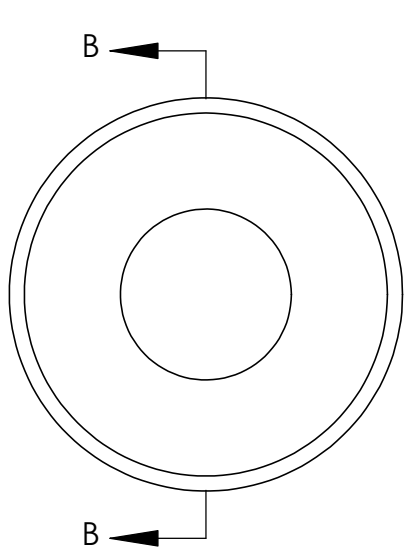
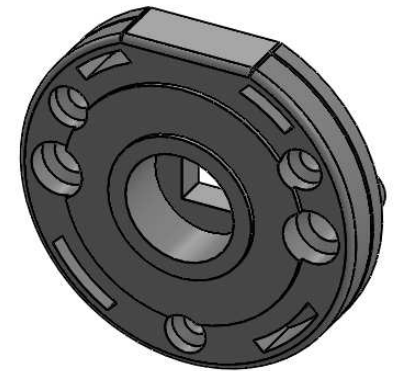
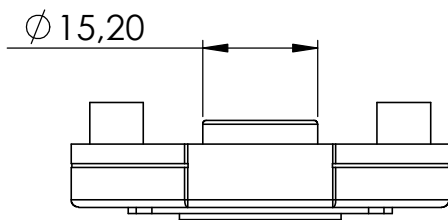
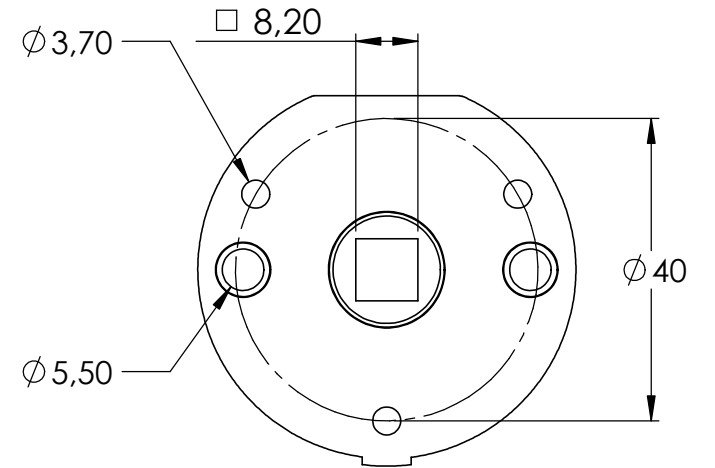
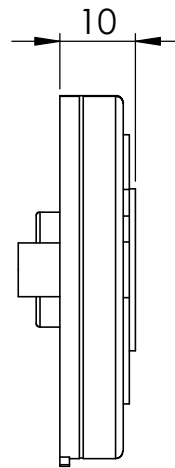
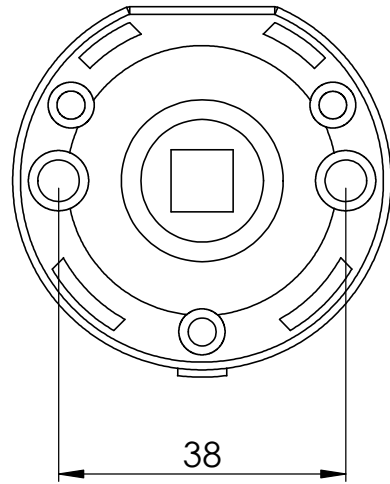
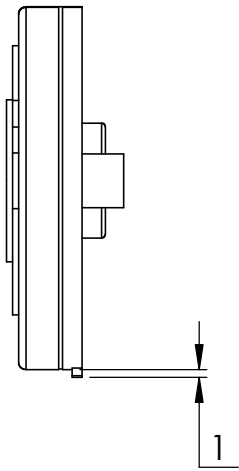
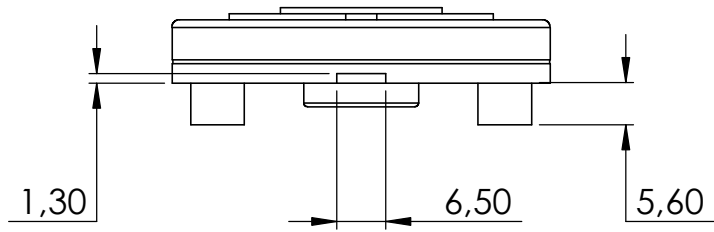
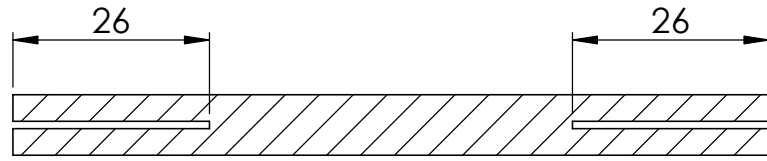

SCHNITT C-C

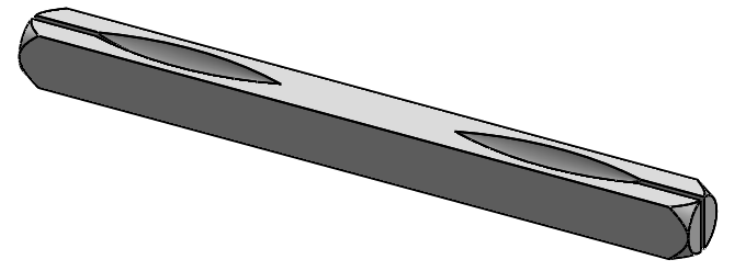
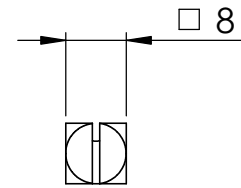
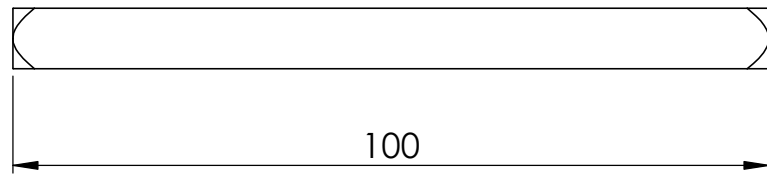
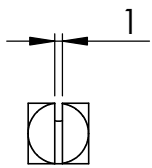

| | | |
|---|--------------|---|
| 4 | 407-VA Teil1 | 2 |
| 5 | DIN 914 M6x6 | 2 |

