

SCHNITT A-A

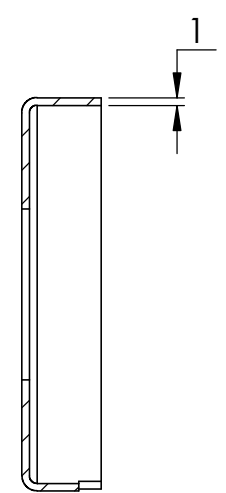

SCHNITT B-B

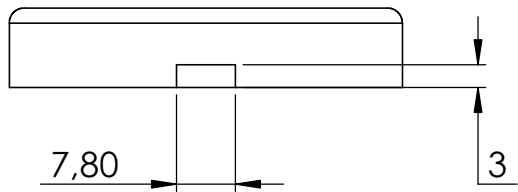

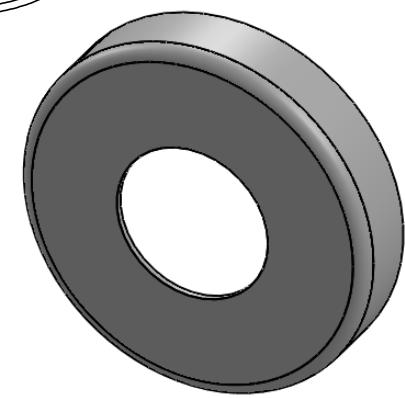
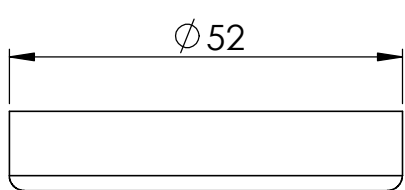
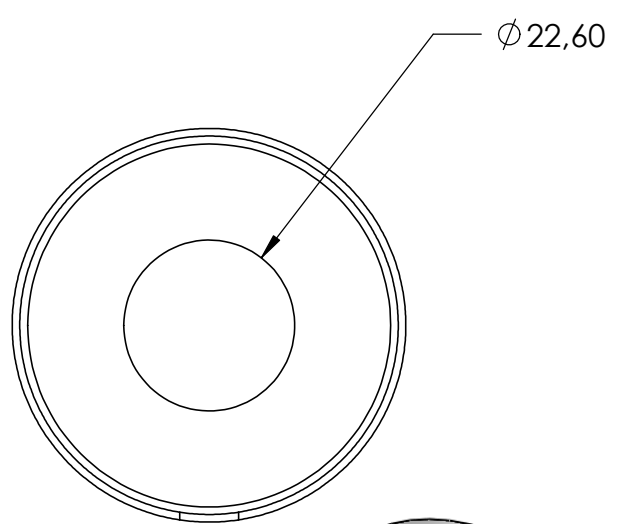
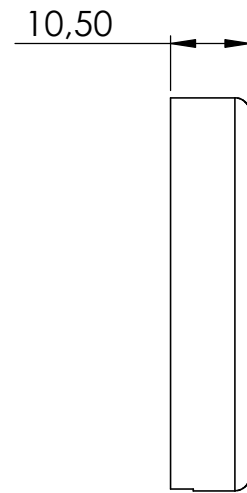
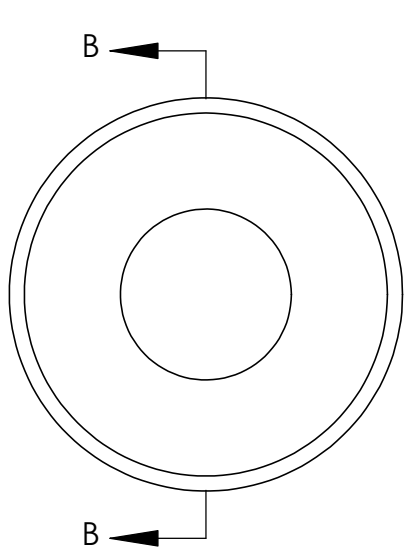
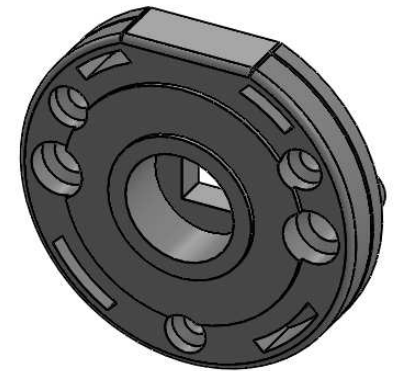
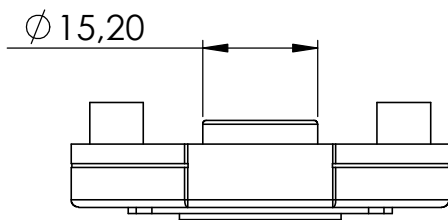
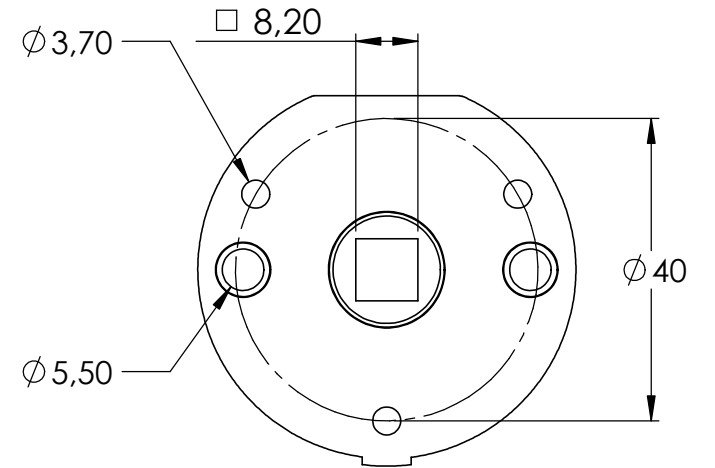
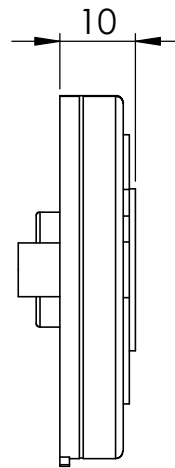
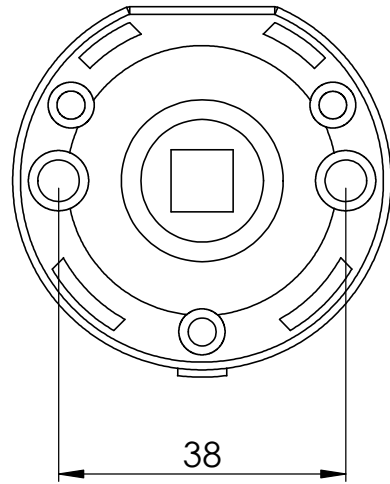
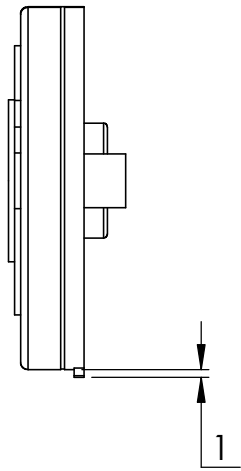
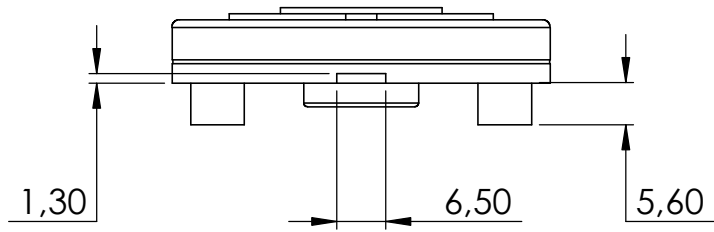

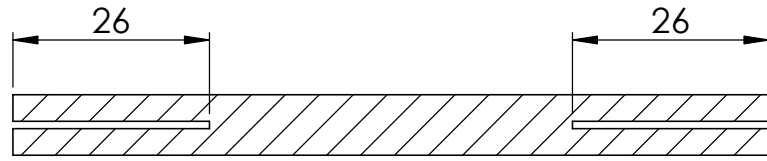

SCHNITT C-C

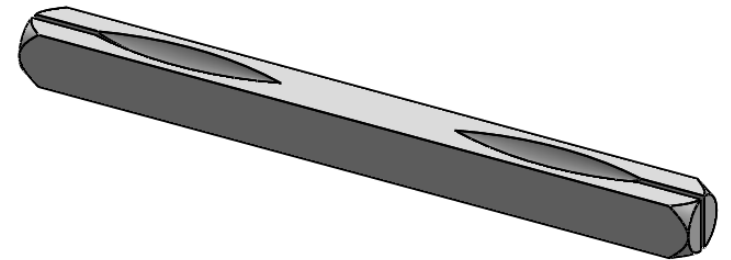
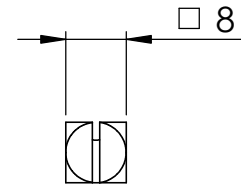
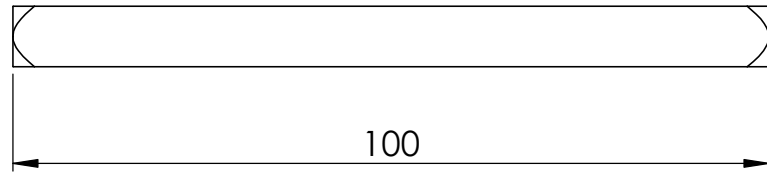
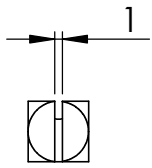

4	410-VA Teil1	2
5	DIN 914 M6x6	2

