

SCHNITT A-A

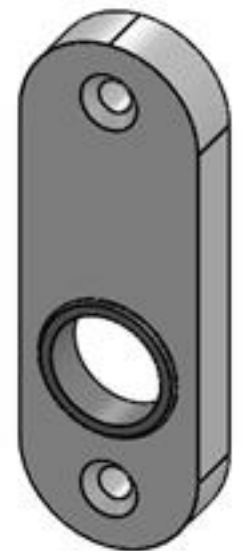
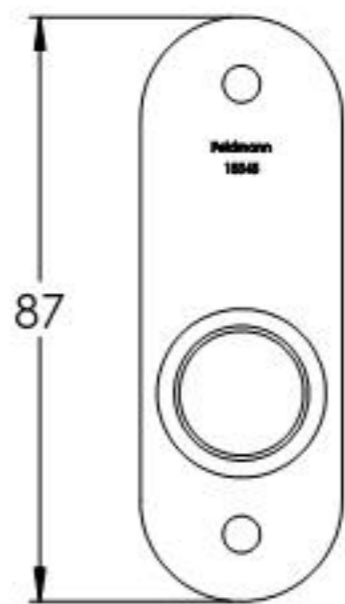
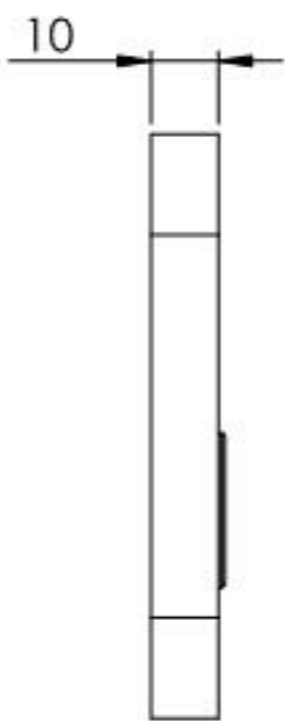
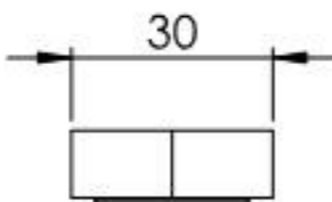
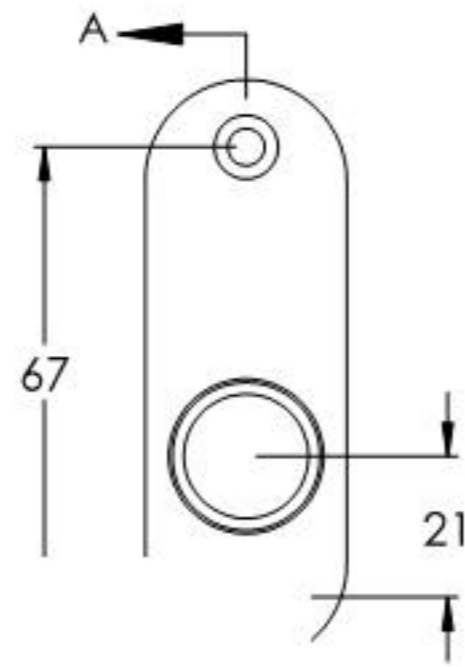

Name	Signatur	Datum	Artikelnummer	Oberfläche: EV I eloxiert
Ch. Höfig	CH	07.10.2020	15545	
Werkstoff: Aluminium [EN AW6060 / 3.3206]		Hersteller		Blattformat
		 Feldmann <small>EDLSTAHL-ALUMINIUM-SCHWEIßEISEN</small>		A4
Gewicht 0.053 kg		Maßstab: 1:1,5	Version: 1	Blatt 1 von 1