

SCHNITT B-B

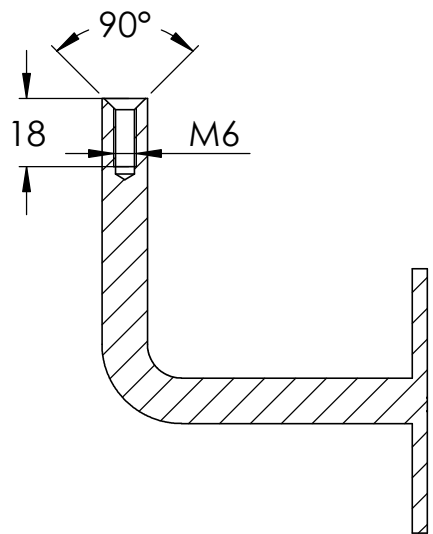

SCHNITT A-A

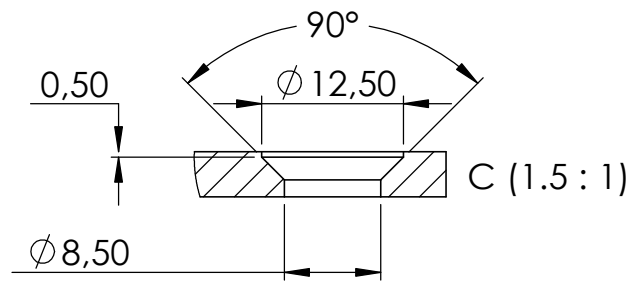