

Name	Signatur	Datum	Artikelnummer	Oberfläche: EV I eloxiert
Ch. Höfig	CH	26.03.2020	BR-F206M8-ALU	
Werkstoff:		Hersteller		Blattformat
Aluminium 6063-T6		 <b>Feldmann</b> <small>EDLSTAHLE · ALUMINIUM · SCHWEIßEISEN</small>		A4
Gewicht 0,060 kg		Maßstab: 1:1	Version: 1	Blatt 1 von 5

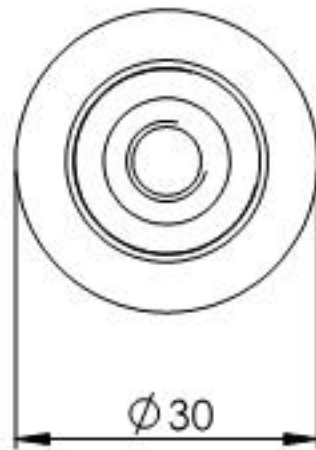

Name	Signatur	Datum	Artikelnummer	Oberfläche: EV 1 eloxiert
Ch. Höfig	CH	26.03.2020	BR-FXXXM8-ALU Teil1	
Werkstoff: Aluminium 6063-T6			Hersteller	Blattformat
			 <b>Feldmann</b> EDLSTAHL-ALUMINIUM-SCHWEIßSTEIN	A4
Gewicht 0,018 kg		Maßstab: 1:1	Version: 1	Blatt 2 von 5

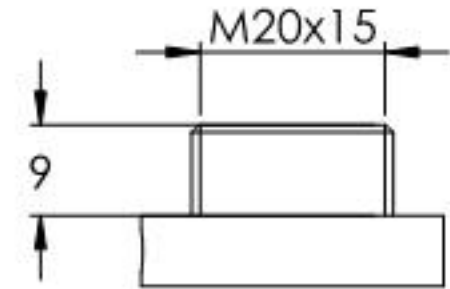
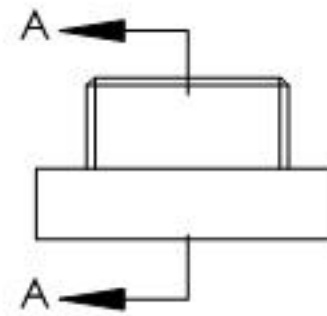
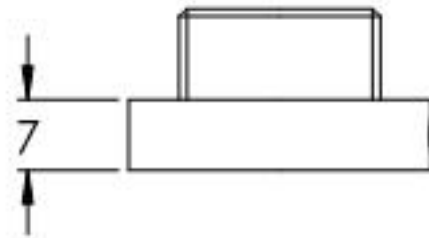
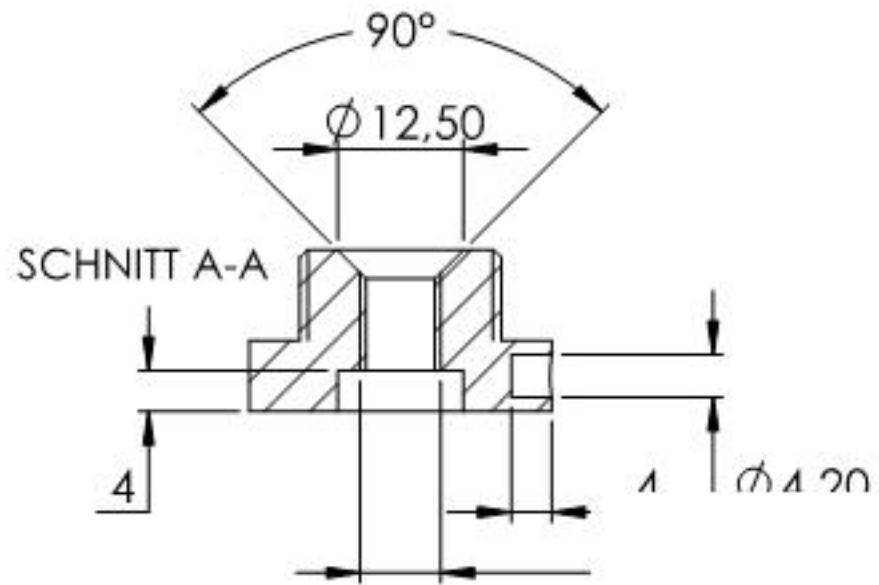
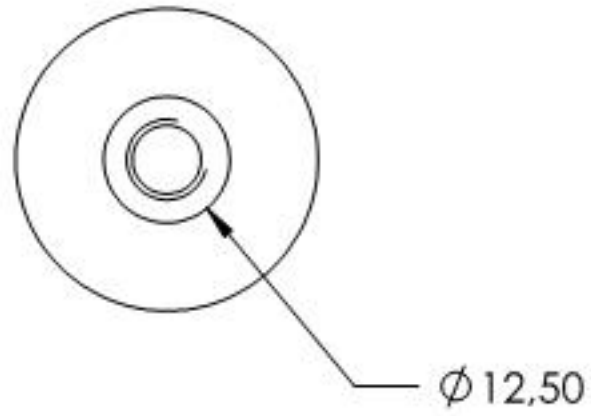
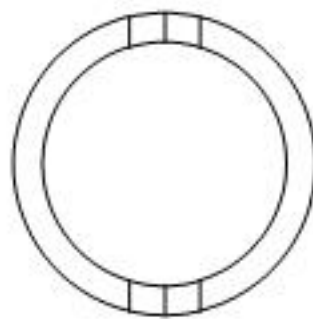
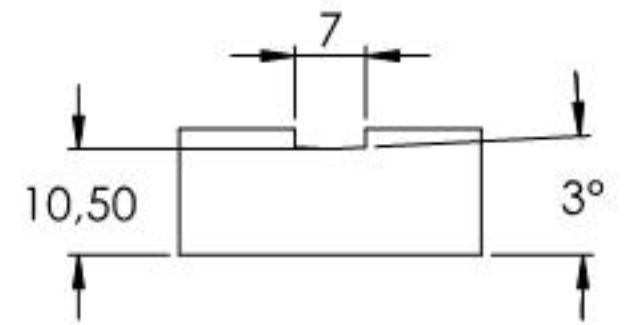
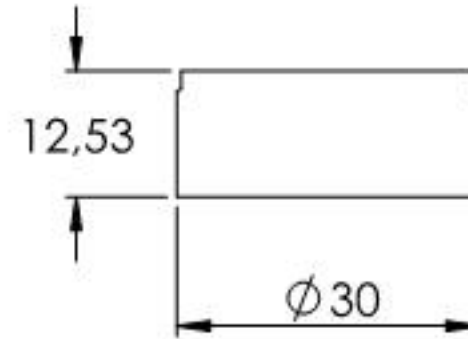
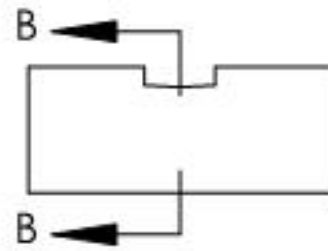
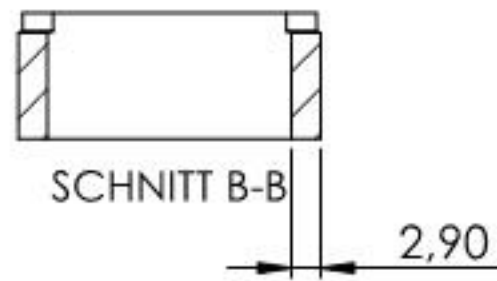
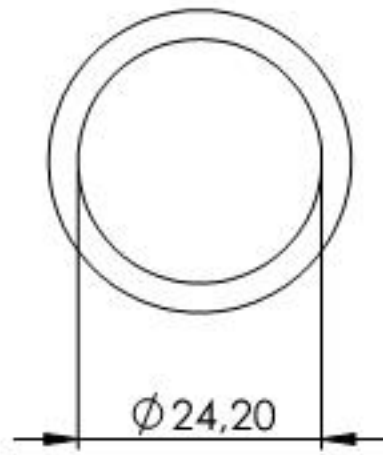

Name	Signatur	Datum	Artikelnummer	Oberfläche: EV 1 eloxiert
Ch. Höfig	CH	26.03.2020	BR-F206M8-ALU Teil2	
Werkstoff: Aluminium 6063-T6			Hersteller	Blattformat
			 <b>Feldmann</b> EDLSTAHLE-ALUMINIUM-SCHWEIßEISEN	A4
Gewicht 0.008 kg			Maßstab: 1:1	Version: 1
			Blatt 3 von 5	