

Name	Signatur	Datum	Artikelnummer	Oberfläche: EV I eloxiert
Ch. Höfig	CH	23.07.2019	BR-F308M8-ALU	
Werkstoff:				Blattformat
Aluminium 6063-T6				A4
Gewicht 0,069 kg		Massstab: 1:1	Version: 1.1	Blatt 1 von 5

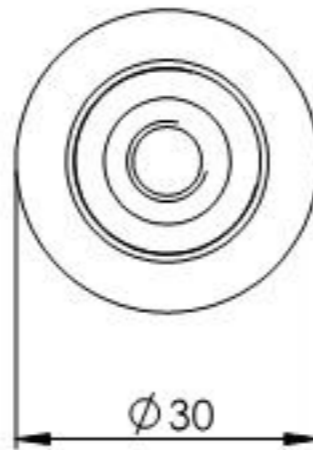

Name	Signatur	Datum	Artikelnummer	Oberfläche: EV I eloxiert
Ch. Höfig	CH	23.07.2019	BR-FXXXM8-ALU Teil1	
Werkstoff:				Blattformat
Aluminium 6063-T6				A4
Gewicht 0,018 kg		Maßstab: 1:1	Version: 1	Blatt 2 von 5

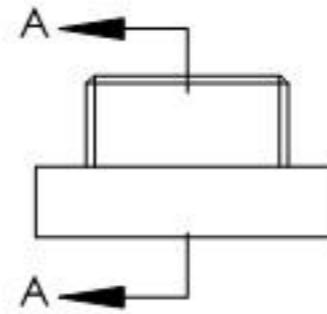
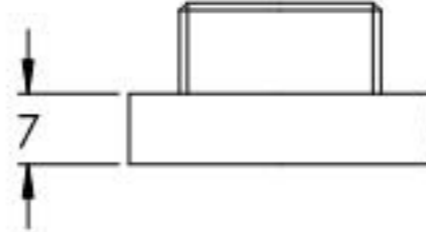
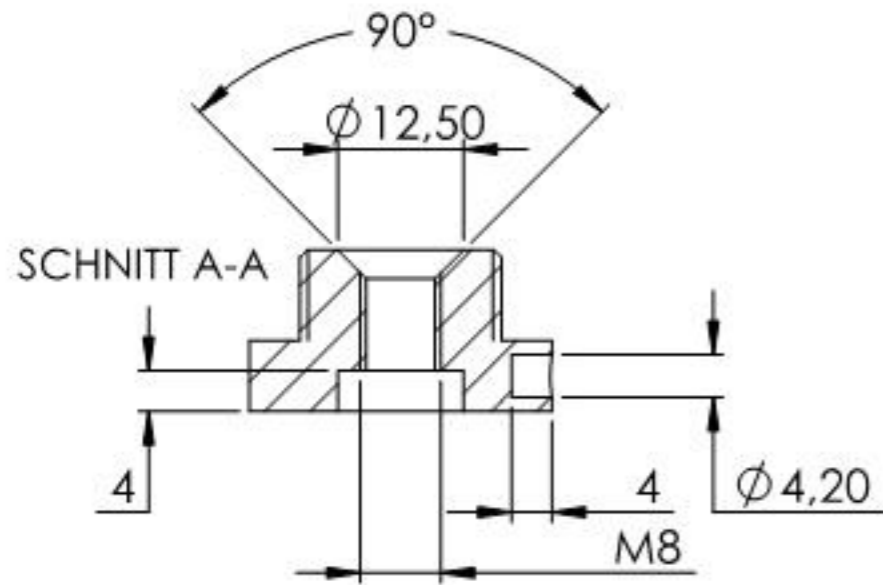
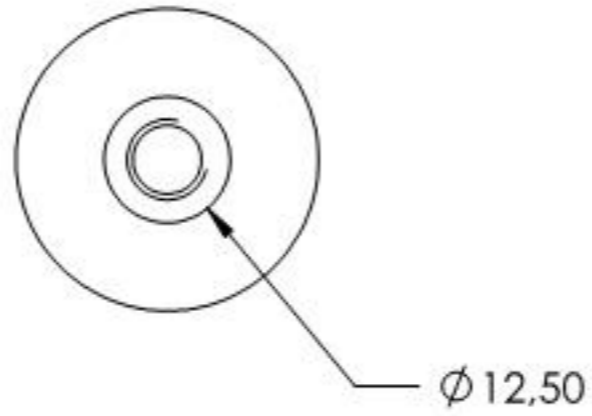
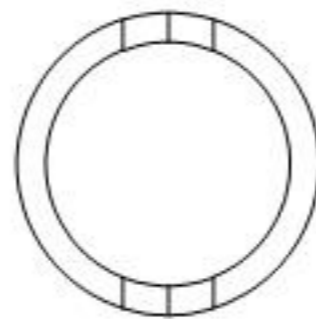
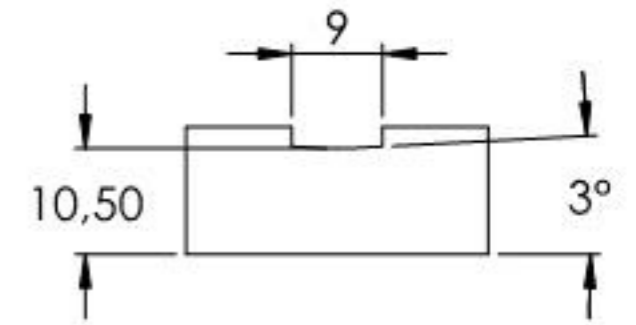
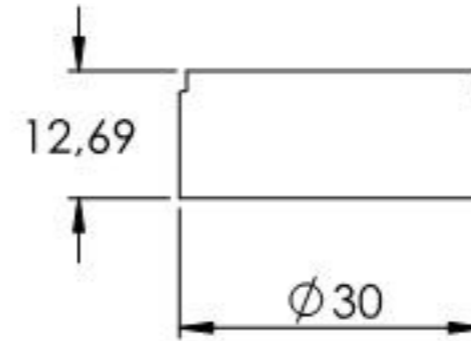
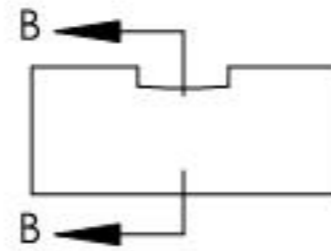
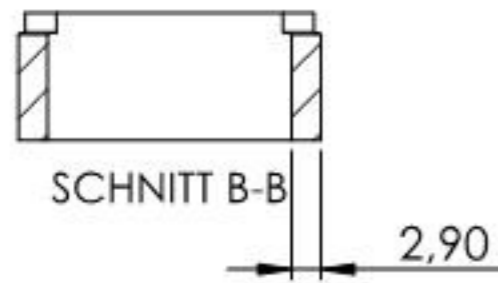
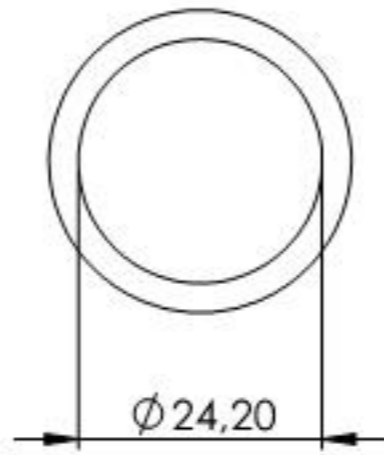

Name	Signatur	Datum	Artikelnummer	Oberfläche: EV 1 eloxiert
Ch. Höfig	CH	23.07.2019	BR-F308M8-ALU Teil2	
Werkstoff:			Blattformat	
Aluminium 6063-T6			A4	
Gewicht 0.008 kg		Maßstab: 1:1	Version: 1.1	Blatt 3 von 5